

SOLUTIONS FOR INTRALOGISTICS



Muvtons Castors was established by Mr. Bhagwan Singh in 1977 with one simple vision: To manufacture wheels & castors that surpass all expectations of quality and performance. Today, having grown to become industry leaders in wheels & castors, we remain committed to that vision as strongly as ever.

We offer the most comprehensive range of solutions for our customers; our products can ferry loads from 100 Kg up to 50 tonnes, and are available in a variety of materials and configurations to fulfil every tenable requirement.

We perform an application study before recommending mobility solutions, employ automated machinery and advanced manufacturing processes, and undertake rigorous in-house product testing to ensure that your investment performs impeccably for years to come.



Mr Bhagwan Singh established Muvtons as a company for manufacturing Elastic Rubber Tyres and Wheels.

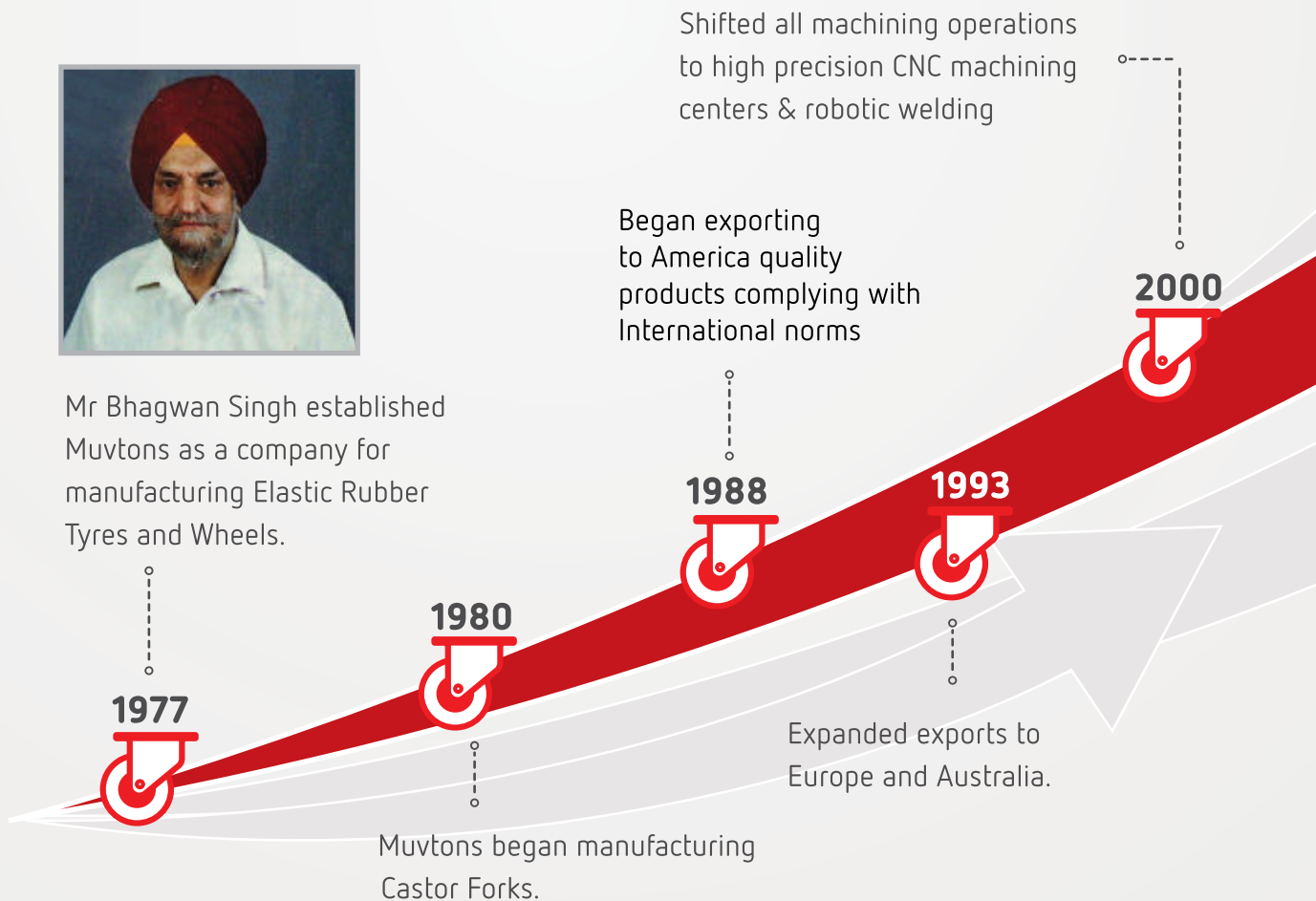

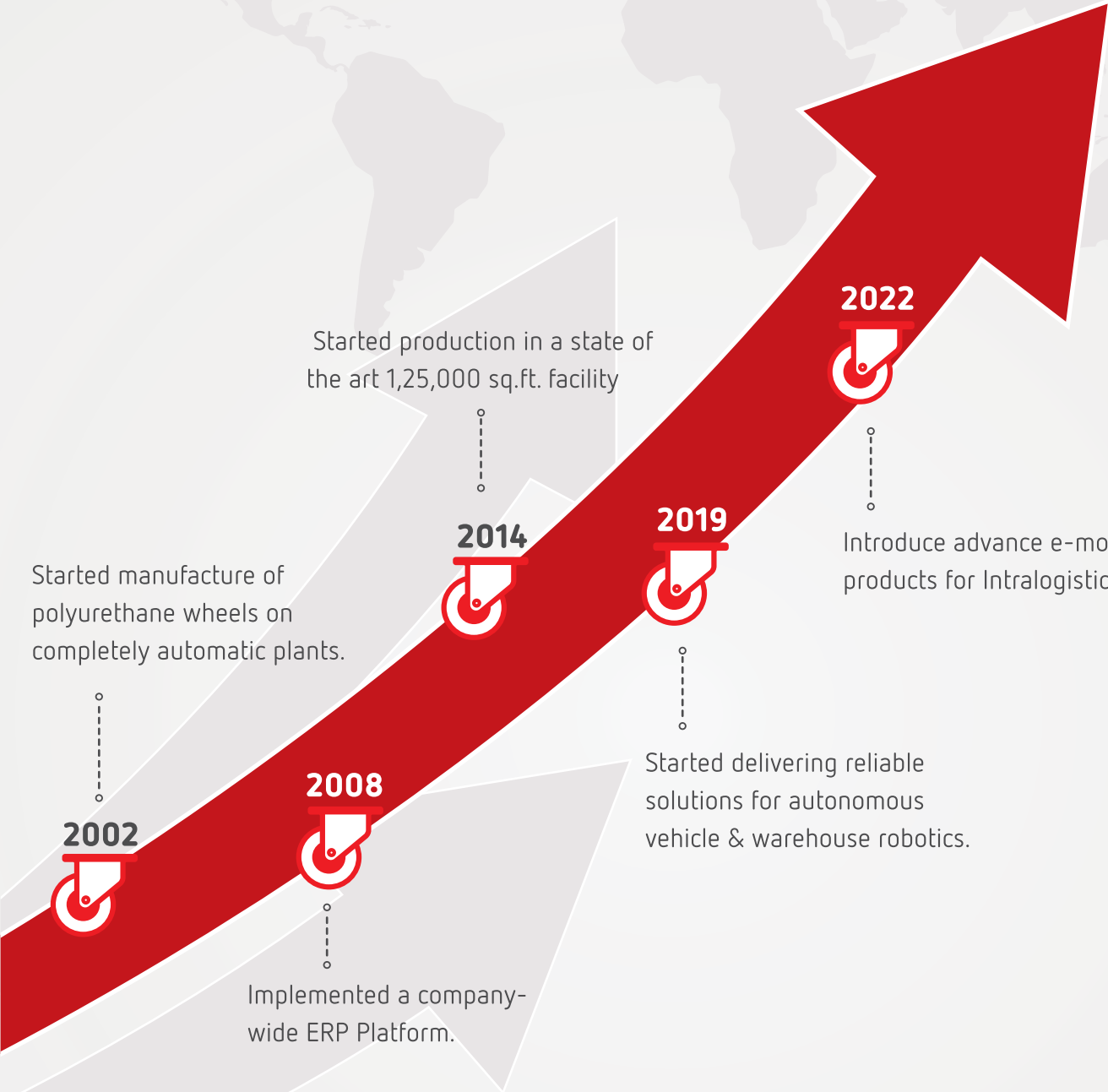

Started manufacture of polyurethane wheels on completely automatic plants.

2002

2008

Implemented a company-wide ERP Platform.

Started production in a state of the art 1,25,000 sq.ft. facility

2014

2019

Started delivering reliable solutions for autonomous vehicle & warehouse robotics.

2022

Introduce advance e-mobility products for Intralogistics



**Moving tons...
So easily...**



World-Class Infrastructure

Muvtons was established on the outskirts of India's capital, New Delhi. Today, we employ more than 200 skilled people on a 1,25,000 sq. ft. in a state of the art integrated manufacturing plant.



World Class Testing Facility

To ensure that we surpass the global quality standards and meet our founders vision of providing highest quality products to our customers.



State of the Art Manufacturing Facility

Equipped with latest advanced machinery to ensure consistent high quality production.

- High-precision CNC Machining Centres,
- Robotic Welding Systems,
- Induction Hardening Equipment, and
- Computer controlled polyurethane wheel molding lines.

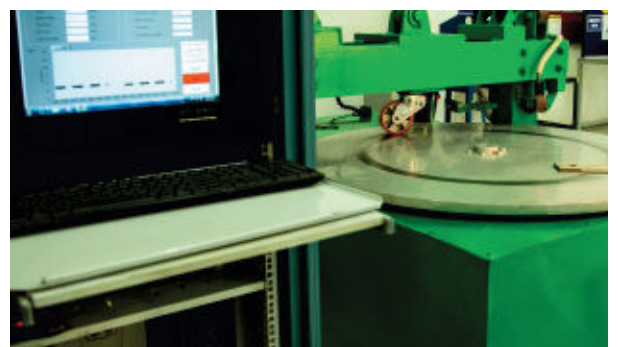

Warehouse

A huge 10,000 sq. mtr of warehousing facility with large stock of standard products to provide short delivery time for customers.



A Young Professional Team

Under the leadership of our dynamic CEO, guided by our founders vision of curating customer's needs. With the culture of customer first, and can do attitude the team is ready to serve the needs of customers with standards as well as customised products in shortest time-line.

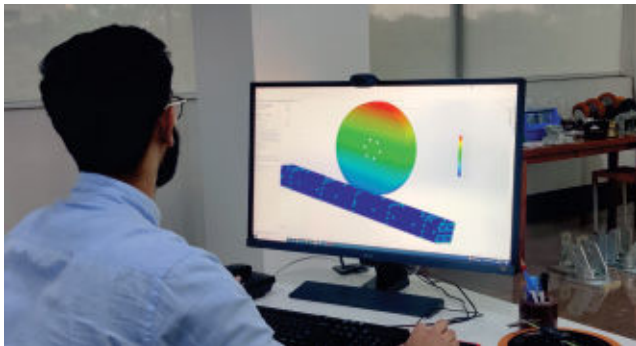

Engineering Resources

A team of highly qualified engineering talent from India's best engineering universities empowered by Muvtons design centre with cutting edge design & innovation tools. This team forms Muvtons backbone for developing high quality and efficient Castors & Wheels.

Comprehensive Product Range

More than 5,000+ products available in variety of materials and configuration, capable of carrying loads up to 50 tons, to quickly provide right solution to a wide range of applications.



CUSTOMISED SOLUTIONS

INNOVATION

COLLABORATION

TIME MANAGEMENT

PRODUCT BREADTH

CUSTOMER SUPPORT

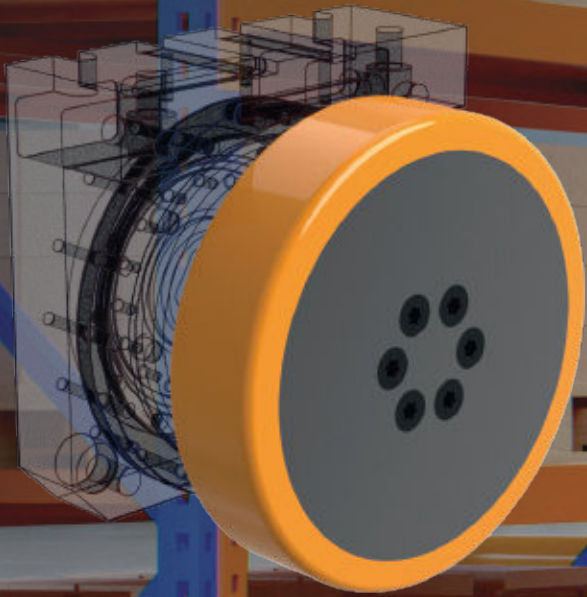

SOLUTIONS FOR YOU



With industry moving towards higher level of automation and Industry 4.0, becoming the norm, the demand for better, faster and reliable mobility solutions are the need of the hour. The Automatic Guided vehicle, robotic and other mobility solutions in intralogistics are expected to carry more loads in a smaller footprint while operating for longer hours in complex environments. In order to operate these machines with better efficiency and durability, one needs wheels and caster solutions that are smaller, ergonomically proficient and attain superlative quality standards.

Muvtons has 45 years' experience of building wheels and casters which surpass global standards. Our highly qualified engineering team supported by world class infrastructure is ideally placed to understand your application. This team can work with your engineering team to develop the best customized castor and wheel solutions for your products. Using the cutting-edge tools, our engineers can do modelling and finite element analysis to ensure that the castor and wheels meets the most stringent requirements. The latest world class test facility, allows us to simulate your required actual conditions and quickly qualify the castors for durability. This facilitates reducing the development time to meet your tight product launch deadlines.

All of the above is further supported and enhanced by – our enduring spirit, nimbleness and flexibility in making us your ideal partner, whether you are building Automatic Guided Vehicles, Robotics or special purpose machines, which require collaboration and sharing of knowledge

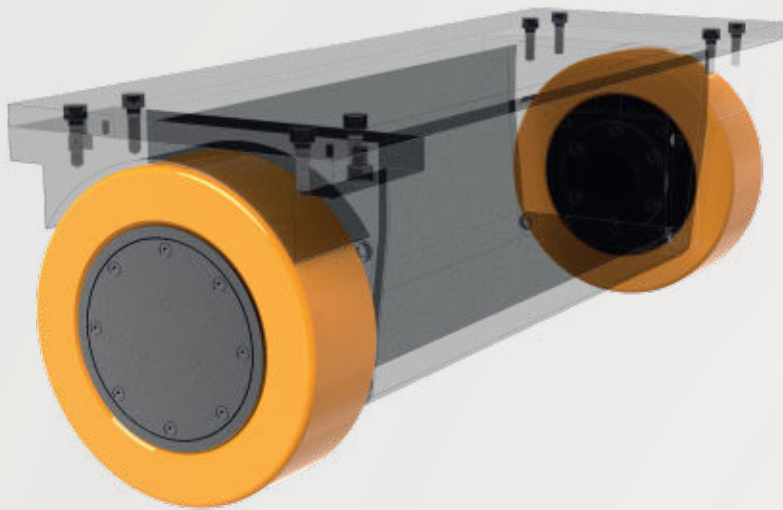

**Customised Drive Wheel
solutions built to meet
Application needs**

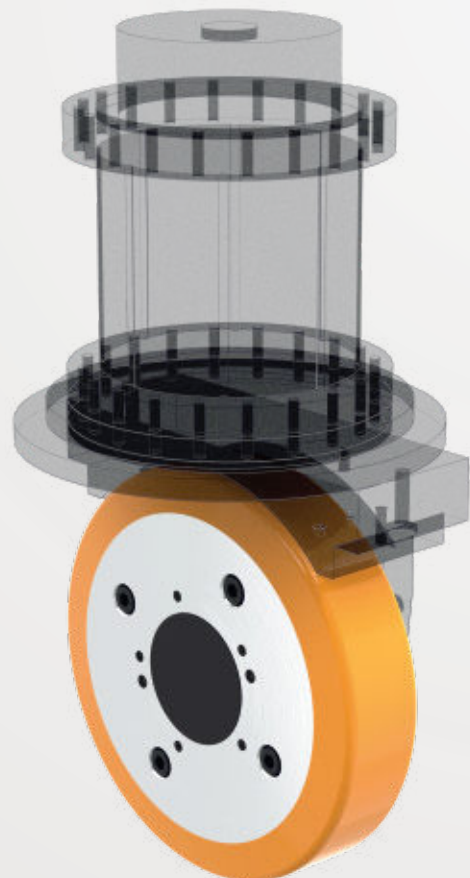
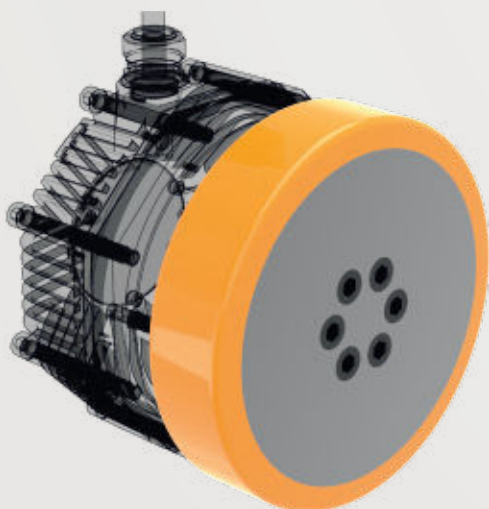
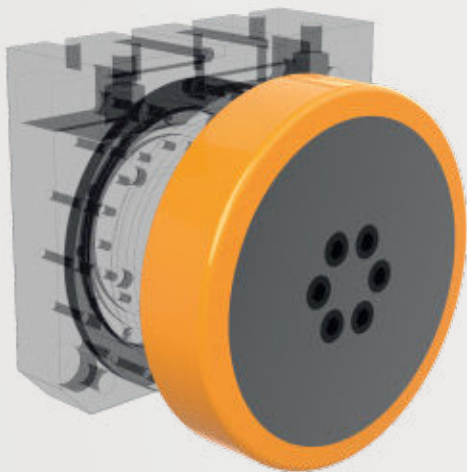

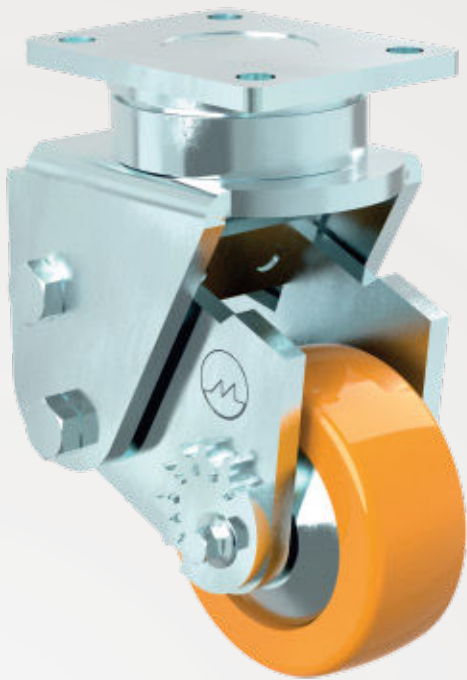

Stabilizing Castors for Lift Trucks

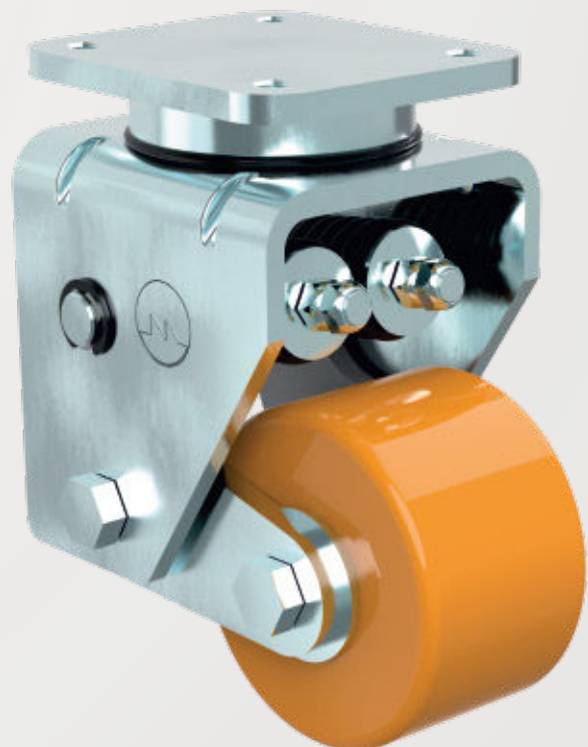
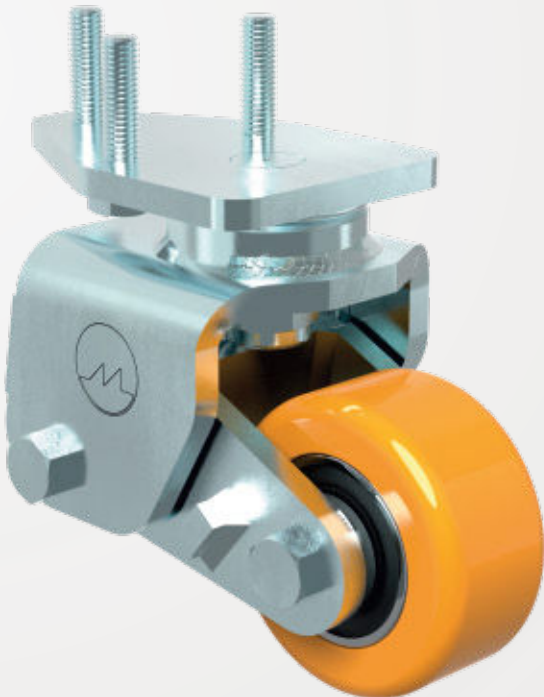

ElectroMuv

Ergonomical

Efficient

Economical

Easy-to-use

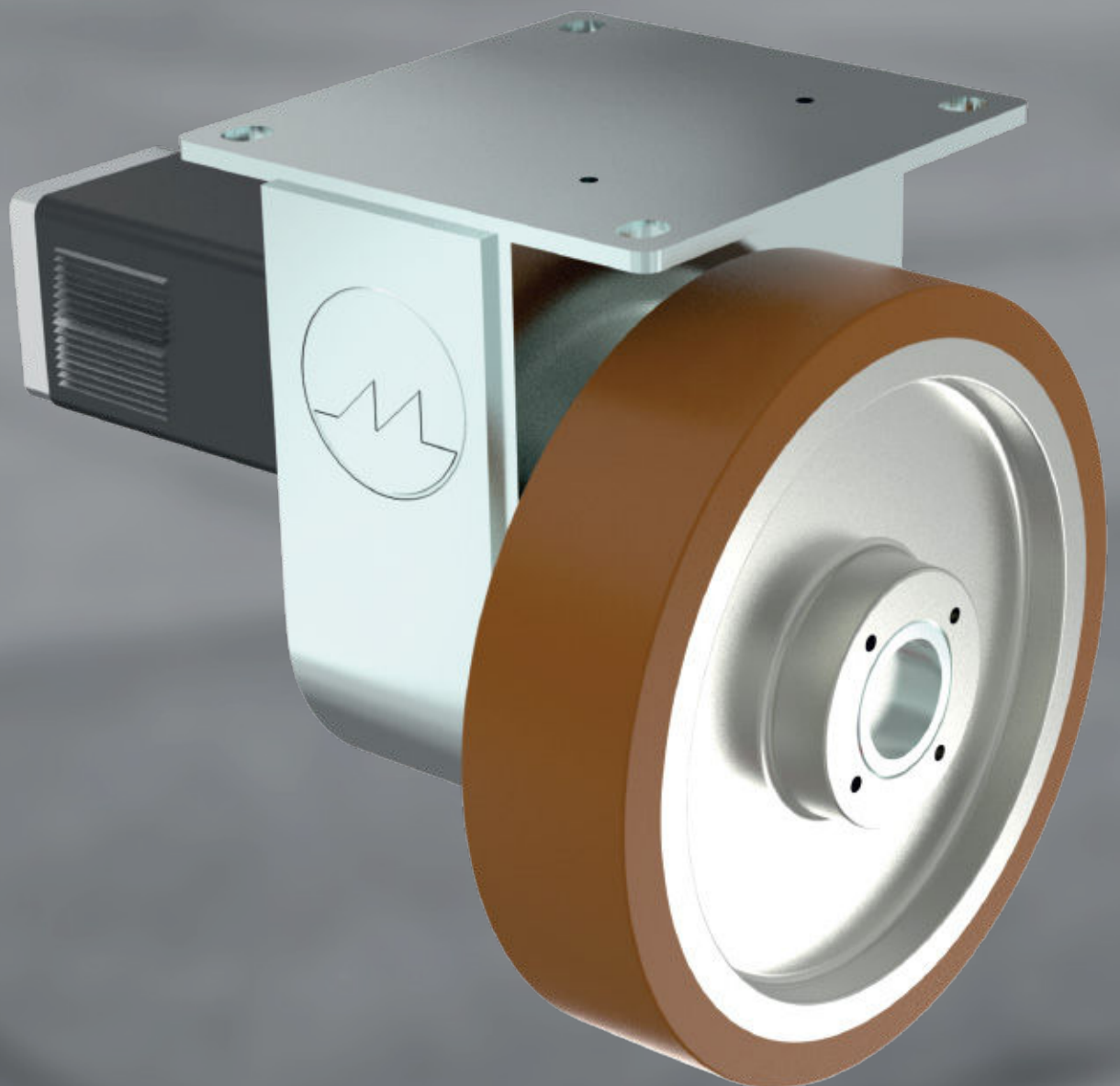

E-mobility solutions from Muvtons

Designed to achieve efficiency in operation by automating the load movement. This economical product not only increases the speed of load movement but also reduces health hazards and safety incidences. The ergonomical design along with efficient motors of ElectroMuv makes it highly energy efficient. Comfortably placed ergonomical grip helps to reduce health risk of the labors. The excellent maneuvering capability makes it ideal even for places with space constraints.

ElectroMuv comes with two fixed motorized battery driven fixed castors along with two swivel castors which require low effort and has excellent maneuverability. ElectroMuv can handle loads up to 4000 kgs. This elegantly designed economical cart is a great add on for your load movements.

ElectroMuv includes: -

- ▶ Powerful motor driven castors for moving heavy loads.
- ▶ Modular Console design with ON/OFF key switch and Battery charge display.
- ▶ Forward/Reverse mode for easy maneuvering.
- ▶ Equipped with emergency Braking System

Advantages:

Ergonomic, safe and easy to use.
Fast Charging.
High Duty Cycle time
Long Battery life.
Efficient.

Options:

- ▶ Compatible swivel castors with varying size and PU hardness.
- ▶ Foot Guard for preventing foot injuries.
- ▶ Dual Charging Unit -for simultaneously charging of two battery units.

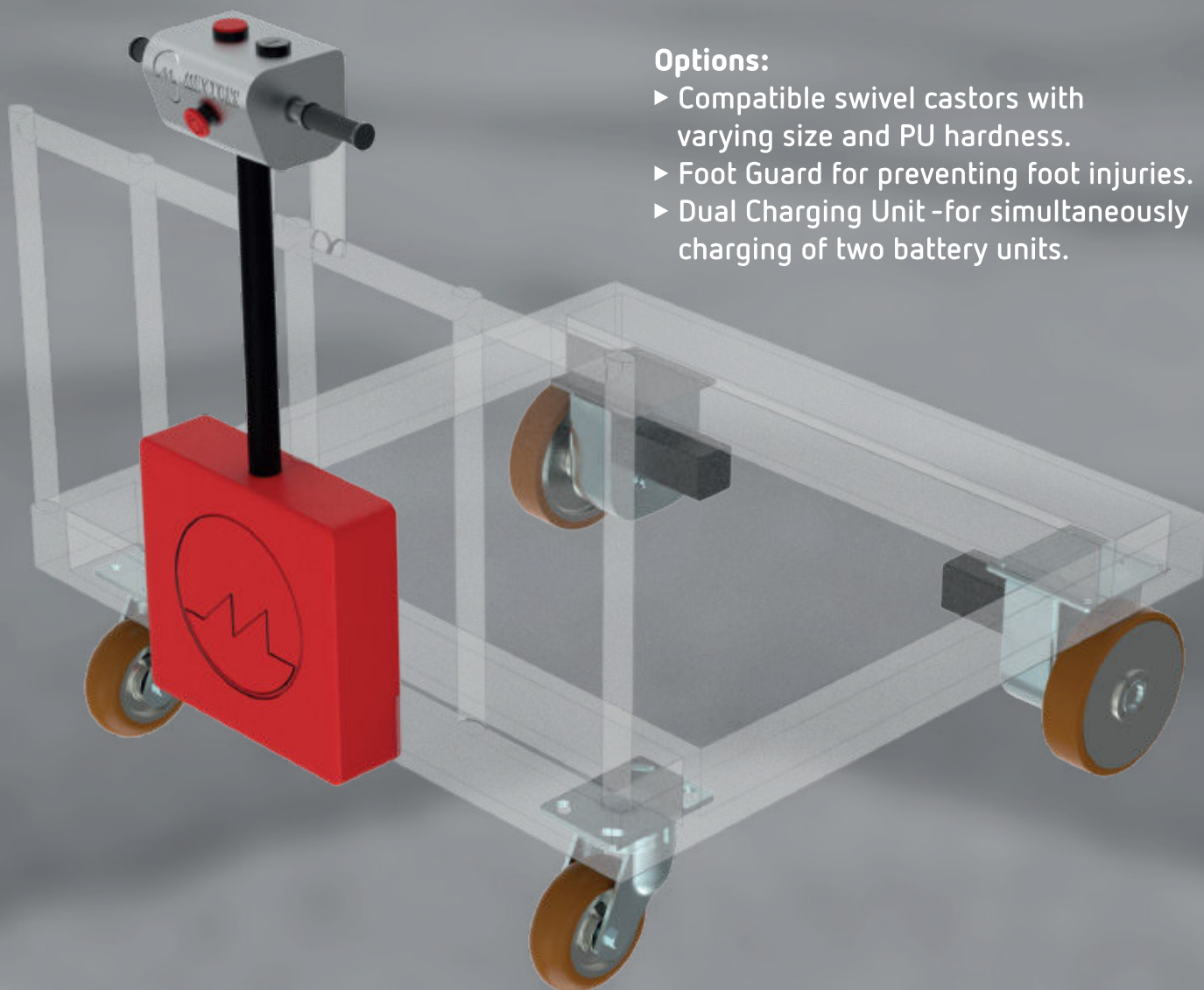



Muvtons Castors Pvt. Ltd.

C-40, Phase-2, Noida-201305, INDIA

 www.muvtons.com

 sales@muvtons.com

 +91 - 991 02 67 000

 +91 - 991 09 66 900